

# PREPARING THE NEXT PHASE OF THE STEADY-STATE MICROBUNCHING PROOF-OF-PRINCIPLE EXPERIMENT AT THE METROLOGY LIGHT SOURCE

A. Kruschinski\*, C. Mai, M. Marongiu, M. Ries, Helmholtz-Zentrum Berlin, Berlin, Germany  
 A. Hoehl, R. Klein, Physikalisch-Technische Bundesanstalt, Berlin, Germany  
 A. Chao, X. Deng, X. Liu, X. Lu, C. Tang, L. Yan, Z. Yang†, Tsinghua University, Beijing, China

## Abstract

Steady-state microbunching (SSMB) is a proposed scheme to generate coherent radiation at short wavelengths from a microbunched electron beam in a storage ring. The feasibility of the idea is investigated in an ongoing proof-of-principle (PoP) experiment conducted at the Metrology Light Source (MLS). Phase I of the SSMB PoP experiment has been using an experimental setup employing a single-shot modulation laser to show the general viability of the idea, and has explored the underlying complex storage ring dynamics. The next step in the SSMB PoP campaign is to progress from the single-shot setup of phase I towards quasi-steady state. To this end, a new laser system is installed at the MLS that can provide turn-by-turn modulation of the electron beam for 1000 revolutions or more. The main goal of this phase II of the SSMB PoP experiment will be to show bounded motion of electrons within individual laser-induced microbunches. In this paper, we show the progress of preparation for PoP phase II, with emphasis on the setup and integration of the new laser system and diagnostics challenges.

## INTRODUCTION

The feasibility of SSMB [1–4] has been explored in a proof-of-principle experiment at the MLS since 2018. The first phase of this experimental campaign has recently been completed after showing the feasibility of generating microbunches using the full circumference of an electron storage ring and exploring the necessary conditions on the accelerator to enable this [5–9]. The next phase of the PoP experiment is currently in preparation. The main goal of PoP phase II is to go towards quasi-steady state and show that electrons can be confined within microbunches by providing a turn-by-turn laser modulation. To this end, a new 6.25 MHz repetition rate laser system was designed and set up at Tsinghua University [10], matching the revolution frequency of the MLS. It is currently being installed into the MLS storage ring bunker. Preparations are also being made to make the accelerator setup and radiation detection scheme ready for the next phase of the SSMB PoP campaign.

## PREPARING THE NEW LASER SYSTEM

The main work in preparation of SSMB PoP phase II at the MLS has been the preparation and installation of the new

laser system. After shipment of the laser to Berlin, it was commissioned in a separate laser lab at the MLS, its beam properties verified and a telescope set up and characterized to ensure the proper focusing of the beam in the center of the MLS undulator.

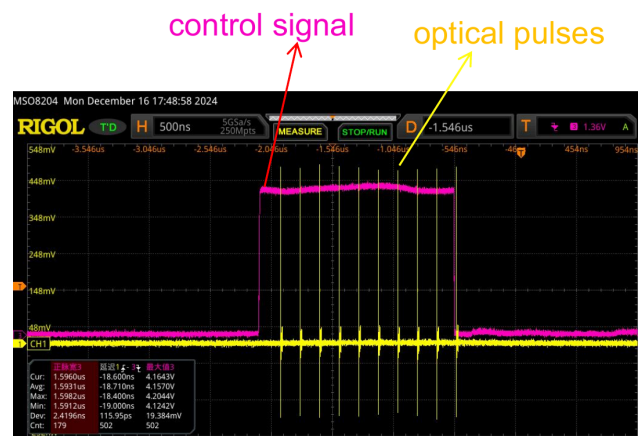

Figure 1: Output of the PoP II laser: Macropulses emitted at a repetition rate on the order of 1 Hz consist of a variable number of micropulses emitted at 6.25 MHz (yellow). The laser supplies a control signal outlining the macropulse to trigger the detection setup (pink).

## Laser Pulse Properties

A phase-stabilized seed laser (wavelength 1064 nm), locked to an Iodine absorption line [11], provides the frequency reference for the laser. On the basis of this seeder, a laser amplifier provides a stream of pulses (width: 0.5 ns, peak radiation power: 25 kW) at a repetition rate of 6.25 MHz. An external trigger derived from the MLS revolution clock can be input to synchronize this repetition rate with the accelerator.

From this stream of micropulses, macropulses are formed consisting of a variable number of micropulses (see Fig. 1 for an example macropulse consisting of 10 micropulses). The laser provides a control signal marking the beginning and end of each macropulse, in order to synchronize the radiation detection setup of the SSMB PoP experiment. In this way, the microbunching properties can be studied for an arbitrary number of consecutive modulation events.

## Installation in the Storage Ring Bunker

The PoP II laser has been moved into the MLS storage ring bunker in August 2025 (see Fig. 2), and installation of the

\* arnold.kruschinski@helmholtz-berlin.de

† yang-z23@mails.tsinghua.edu.cn

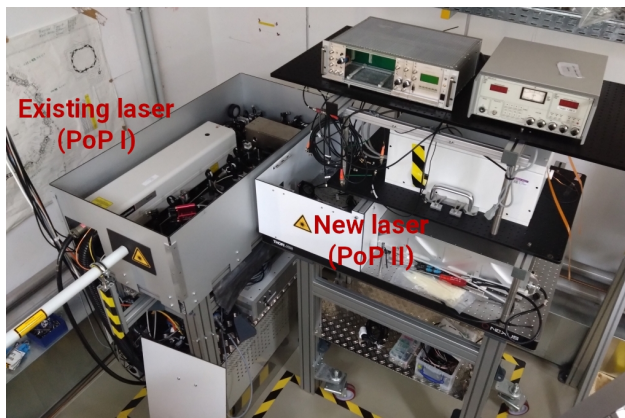

Figure 2: Photo of the new laser system installed in the storage ring bunker.

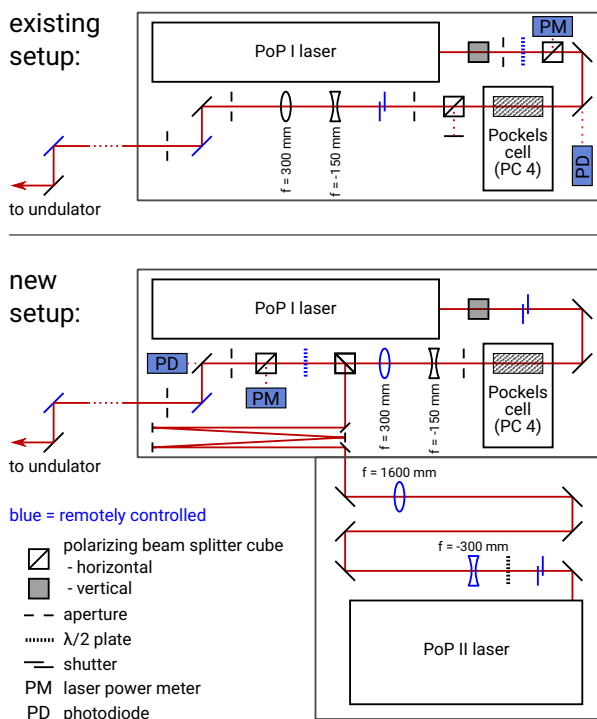

Figure 3: Sketch of the existing PoP I laser setup and its alteration to incorporate the new PoP II laser system on an additional optical table.

optical beam path is ongoing. A sketch of the planned setup is shown in Fig. 3. The aim of the new laser setup is to enable operation of both the existing PoP I laser system and the new PoP II laser system with minimal switching effort. This is achieved by imposing perpendicular linear polarizations for both lasers, combining the laser beams in a polarizing beam splitter, and then employing a motorized half-wave plate to select the proper final polarization. Physically, the new laser is installed on a separate optical table containing also the new telescope setup, with some modifications necessary on the existing optical table to accommodate the optics to combine the two lasers.

## Telescope Setup and Laser Waist Properties

The telescope to focus the PoP II laser beam at the center of the undulator (some 8 m from the exit of the optical table sketched in Fig. 3) consists of a concave and convex lens of rather large focal lengths and distance between them, in order to achieve the desired beam waist properties. This requires long delay lines formed with a number of mirrors (see Fig. 3). It was also considered to design a setup that includes the telescope used for the old laser system, in order to make use of as many of the existing and pre-aligned optical elements as possible. However, it was found it is not possible to achieve the desired focusing in this way, due to the short focal lengths of the existing lenses. A Rayleigh length of  $z_R = 1.5$  m would be optimal to maximize the energy modulation of the electron beam considering the undulator length of 4 m. With the prepared new telescope, a Rayleigh length of  $z_R \approx 1.6$  m has been achieved, with a measured  $M_{x,y}^2 \approx 1.3$  showing good beam quality (see Fig. 4).

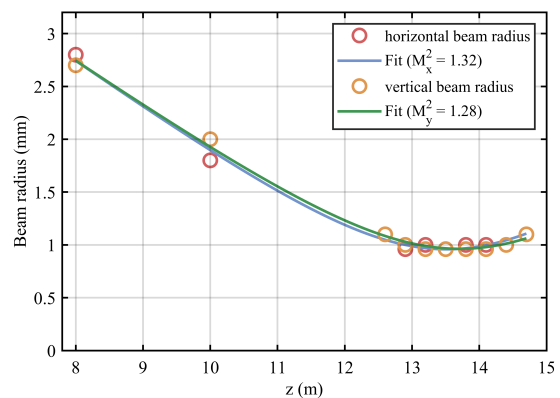

Figure 4:  $M^2$  measurement of the PoP II laser with the telescope setup used to focus the beam to the undulator center at  $z \approx 13.5$  m from the laser output aperture.

## PREPARING THE ACCELERATOR

### Orbit Control with Constant RF Frequency

The requirements on the accelerator setup for PoP phase II are similar to what is already established for PoP phase I. However, one important change has to be made: In order for the phase of the turn-by-turn energy modulation to remain constant, the rf frequency must not be changed during PoP II experiments. So far, a controller acting on the rf frequency has been used to control orbit deviations, so instead, an orbit controller acting on a closed four-steerer-bump has been developed and successfully tested to be used for the PoP II experiments.

### Optimizing Setup for Maximum Microbunching

During the PoP I experiment campaign, the setup of the MLS storage ring to optimize the microbunching formation has been well understood [8]. One additional parameter has been identified for optimization: by reducing the cavity

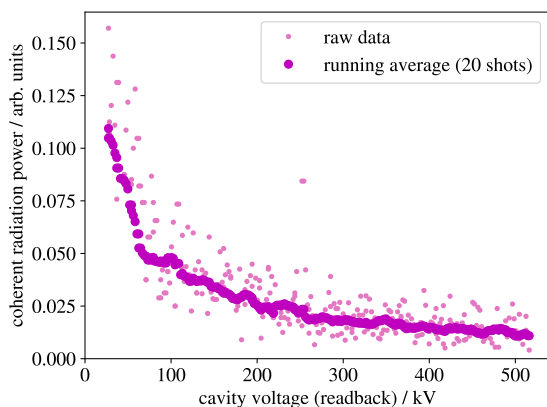

Figure 5: Optimization of coherent radiation signal: By reducing rf cavity voltage, the beam energy spread is reduced, improving the microbunch formation. Bunch charge: 5 pC

voltage as low as possible (below 25 kV, operation tends to become unstable), the coherent radiation power in the experiment can be maximized (see Fig. 5). This is most effective at moderate to high bunch charges ( $> 1$  pC), where the induced bunch lengthening leads to a significantly reduced energy spread, which is beneficial for microbunching formation.

## PREPARING THE DETECTION SETUP

The existing setup to detect the coherent undulator radiation generated from the microbunched electron beam in the SSMB PoP experiment is also well proven [12]. It already employs the necessary electro-optical switching setup to block the modulation laser and a very sensitive detector. Nevertheless, in anticipation of reduced signal amplitudes for PoP phase II due to the strongly reduced modulation laser power, measures to improve signal intensity were considered.

The setup contains a narrow bandpass filter (currently 3 nm bandwidth) to help distinguish the narrow band coherent radiation from the incoherent undulator radiation. This filter was exchanged for the most narrow available filter (bandwidth 1 nm) to improve this distinction. Also, a telescope setup to collimate the undulator radiation and improve the geometrical acceptance of the setup was designed and tested. However, both measures did not provide a significant improvement of signal intensity or quality.

To simulate the conditions of PoP phase II, a test experiment was conducted using the PoP I laser attenuated to about 1/1000 of its nominal power level, which is comparable to the laser power level expected for the PoP II laser. Even under these conditions, a clear coherent undulator radiation signal was obtained for medium to high electron beam currents (bunch charge  $> 20$  pC), so the existing setup is sensitive enough for the PoP phase II experiments.

Since the observation of coherent emission is only possible once the laser modulation has ceased, it is currently planned to observe the undulator radiation after a variable number of revolutions with modulation and comparing with

theoretical predictions in order to show that electrons are confined to microbunches. An oscillation pattern should be visible that is related to the synchrotron oscillation frequency within the microbunches.

## Triggering Scheme for PoP Phase II

The triggering scheme for the detection setup including the active optics (Pockels cells 1-3) has to be adapted for experiments with the new laser system. As there are no significant changes to the detection setup, the triggering scheme (compare [12]) has to be altered only to accommodate the new trigger source from the control signal of the PoP II laser (see Fig. 1). The final triggering scheme is shown in Fig. 6. Switching between the PoP I and PoP II laser systems will be possible by exchanging one signal cable and altering the settings of one delay generator.

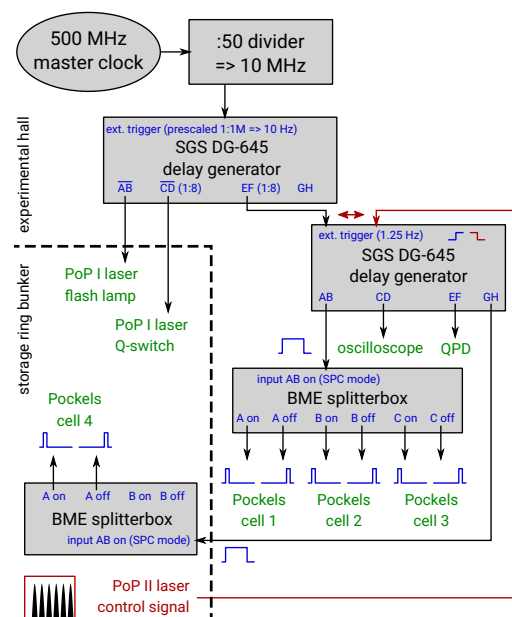

Figure 6: Sketch of the triggering scheme enabling both PoP I and PoP II laser operation. To switch between the laser systems, the input trigger of the second delay generator has to be exchanged (red arrow).

## CONCLUSION

Setup and integration of the new laser system is still ongoing. Proper focusing optics for the new laser system have been prepared. The existing radiation detection setup has been shown to be sensitive enough for the expected reduced signal magnitudes, and is thus ready for SSMB PoP phase II experiments, as is the accelerator, where the small necessary changes to the machine setup have already been proven feasible. As such, it is currently expected that experiments utilizing the new laser system can commence in the last quarter of this year, with the goal of establishing a quasi-steady state microbunched beam at the MLS.

## REFERENCES

- [1] D. F. Ratner and A. W. Chao, “Steady-state microbunching in a storage ring for generating coherent radiation”, *Phys. Rev. Lett.*, vol. 105, p. 154801, 2010.  
doi:10.1103/PhysRevLett.105.154801
- [2] X. J. Deng *et al.*, “Average and statistical properties of coherent radiation from steady-state microbunching”, *J. Synchrotron Radiat.*, vol. 30, pp. 35–50, 2023.  
doi:10.1107/S1600577522009973
- [3] Z. Li, X. Deng, Z. Pan, C. Tang, and A. Chao, “Generalized longitudinal strong focusing in a steady-state microbunching storage ring”, *Phys. Rev. Accel. Beams*, vol. 26, p. 110701, 2023. doi:10.1103/PhysRevAccelBeams.26.110701
- [4] X. Deng, *Theoretical and Experimental Studies on Steady-State Microbunching*. Springer, 2024.  
doi:10.1007/978-981-99-5800-9
- [5] X. Deng *et al.*, “Experimental demonstration of the mechanism of steady-state microbunching”, *Nature*, vol. 590, pp. 576–579, 2021.  
doi:10.1038/s41586-021-03203-0
- [6] A. Kruschinski *et al.*, “Exploring the necessary conditions for steady-state microbunching at the metrology light source”, in *Proc. IPAC’23*, Venice, Italy, May 2023, pp. 464–467.  
doi:10.18429/JACoW-IPAC2023-MOPA176
- [7] A. Kruschinski *et al.*, “Confirming the theoretical foundation of steady-state microbunching”, *Commun. Phys.*, vol. 7, p. 160, 2024. doi:10.1038/s42005-024-01657-y
- [8] A. Kruschinski, “Exploring necessary conditions for generating coherent radiation from microbunching at the metrology light source”, Ph.D. dissertation, Humboldt-Universität zu Berlin, 2025. doi:10.18452/33089
- [9] A. Kruschinski, J. Feikes, A. Hoehl, R. Klein, and X. Deng, “Laser modulator for SSMB used as a diagnostic tool”, in *Proc. IBIC’24*, Beijing, China, Sep. 2024, pp. 464–468.  
doi:10.18429/JACoW-IBIC2024-THBC3
- [10] X. Lu, X. Liu, Q. Tian, H. Wang, and L. Yan, “An electron beam modulation laser for steady-state microbunching”, in *Proc. IPAC’24*, Nashville, TN, USA, May 2024, pp. 1392–1395. doi:10.18429/JACoW-IPAC2024-TUPG72
- [11] A. Arie, S. Schiller, E. K. Gustafson, and R. L. Byer, “Absolute frequency stabilization of diode-laser-pumped Nd:YAG lasers to hyperfine transitions in molecular iodine”, *Opt. Lett.*, vol. 17, no. 17, pp. 1204–1206, 1992.  
doi:10.1364/OL.17.001204
- [12] A. Kruschinski, R. Klein, A. Hoehl, J. Feikes, and J. Li, “Improved signal detection of the steady-state microbunching experiment at the metrology light source”, in *Proc. IPAC’23*, Venice, Italy, May 2023, pp. 461–463.  
doi:10.18429/JACoW-IPAC2023-MOPA175